

Product Information

Active Receiving Crossed Dipole Antenna HD 2 A

This antenna is an active dipole receiving antenna for the medium- and short-wave bands. The main advantage of the active crossed dipole antenna HD 2 A is its extremely large bandwidth and dynamic range. The antenna is ideal for applications requiring reception over a large frequency range (1.5 - 30 MHz).

The very small dimensions and associated low weight makes this antenna ideal for both stationary - where space is at a premium - and transportable applications.

The system can be extended to a receiving antenna system for vertical and horizontal polarization, if necessary also subsequently, by combination with an active monopole (e.g. STA .. A/ . / 0.01-30).

The antenna amplifiers for the two horizontal dipoles are installed in a watertight and seawater resistant cast aluminum alloy housing, the antenna head. The antenna rods are made of glass fiber reinforced plastic fitted with stainless steel screw connections.

The cable connectors are fitted to the bottom side of the antenna head's bottom flange. It is protected against the environment by means of a trumpet shaped mounting support (the funnel) which is mounted to the bottom flange of the antenna head. The opposite end of the funnel fits the size of 2" supporting pipes.



Regarding the robust construction and the use of weatherproof materials our active antennas can be used under extreme environmental conditions.

The nominal operating voltage for the antenna is 39 Vdc. The AAN power supply series or an aas.tech Antenna Distribution System is used to feed the operating voltage to the active element via the coaxial cable.

Technical Data

Parameter	Data
Application	active symmetrical dipole antenna
Characteristic	crossed horizontally polarized dipole antenna
Color	RAL 7035
Bending moment at mounting flange	1 daNm (wind speed 150 km/h)
Shock test	50 g / 10ms
Vibration test	4 – 12,5 Hz amplitude = 1,6 mm 12,5 - 90 Hz acceleration 10 m/s ²
Ambient temperature	-40°C ... +70°C
Storage temperature	-55°C ... +80°C
Relative humidity	100%
EMP test	STANAG 4145
Lightning protection	500 kV/m/μs
RF connector	2 N sockets
Power supply	39 Vdc power feeding through coaxial cable
MTBF	> 36.000 h (Tu = 40°C)
MTTR (replacement of subassemblies)	1,0 h
Frequency range	1,5 - 30 MHz
Output impedance	50 Ω
Effective height at 50 Ω	55 cm (tolerance ± 1,5 dB)
Intermodulation 2nd order (E1=E2=100 mV/m)	≥ 70 dB
Intermodulation 3rd order (E1=E2=100 mV/m)	≥ 110 dB
Equivalent noise field strength (limit of sensitivity B=1 Hz)	≤ 0,015 μV/m
Sensitivity (B=3 kHz, S/N=10 dB)	≤ 2,6 μV/m
Cross modulation (causing 10 % modulation)	≥ 5,2 V/m
Max. tolerable field strength (1dB reduction of gain)	≥ 8,0 V/m

Data given without tolerance are typical values.

Design and specification are subject to change without prior notice, errors excepted.

Scope of Supply

Pos.	Description
1	Active Receiving Antenna HD 2 A
2	Accessory Set ZS 13
3	USB stick with product documentation in pdf format

Dimensions and Weight

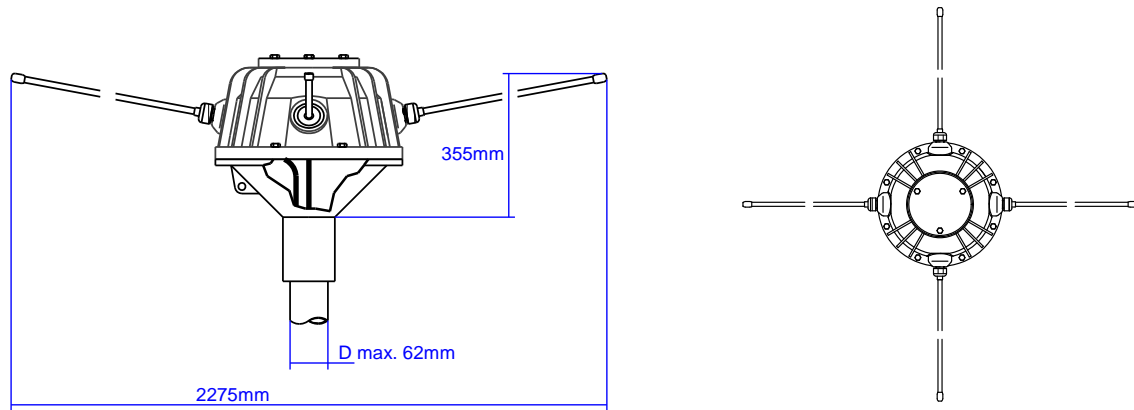

12,0 kg

Accessories

Type Designation	Part No.	Description
ZS 13	0028.3713.00	Accessory set consisting of - 2 ea. N male plug Part No. ST.0015 - 2 ea. Rubber sleeve for N plug black Part No. A.0047

Variants and Order Information

Type Designation	Part No.	Description
HD 2 A	0005.6620.00	Active Antenna System, RAL 7035

Other variants are available on request.

Options

Option	Part No.	Description
RAL Color Code	depends on RAL color code	Painting in RAL color according to customer specification

Other or customer specific options are available on request.

Spare Parts

Applicable for

Active 2 Dipole Antenna HD 2 A

No.	Designation Type	Part-Number NSN	Max. Qty. (a)	MTBF/hrs MTTR/hrs	Dimensions/mm Weight/kg (b)	Qty (c) Qty (d)	Remark
1	Flat gasket 11	0005.6602.08 5330-12-320-6337	1	- -	270x3 0,05	- 1	
2	Flat gasket 12	0005.6602.09 5330-12-319-8961	1	- -	310x3 0,06	1 1	
3	Antenna rod STA 10	0005.4202.00 5985-12-314-0516	4	130.000 -	32x970 0,30	1 1	
4	Active element AE DC	0005.6604.00	1	40.000 -	200x200x50 0,70	- 1	
5	Manual HD 2 A	056620		- -	DIN A4		Printed issue

- (a) Maximum quantity per equipment
- (b) Dimensions and weight are without packing
- (c) Recommended quantity per equipment for 90 days on board
- (d) Recommended quantity per equipment for 3 years depot

Note:

The spare part table is applicable for versions in standard color (similar RAL7035). Spare parts (housing, mast adapter, rods) in other colors are available.

Associated Products

For integration into the application environment associated products are available.

Type Designation	Part No. NSN	Description
AAN 120	2061.0120.00	<p>19-inch 1 HU Remote Power Supply Unit Frequency range 0.01 – 100 MHz</p> <p>The AAN 120 provides 2 remote power feeding ports and 2 receiver ports, typically used with 2 active monopole antennas STA or 2 active dipole antennas HD 1 A or 1 active dipole antenna HD 2 A.</p> <p>Doc. PIG 010620</p>
AAN 130	2061.0130.00	<p>19-inch 1 HU Remote Power Supply Unit Frequency range 0.01 – 100 MHz</p> <p>The AAN 130 provides 3 remote power feeding ports and 3 receiver ports, typically used with 3 active monopole antennas STA or 2 active dipole antennas HD 1 A or 1 active dipole antenna HD 2 A or 1 active combination antenna HD 2 A + STA ...</p> <p>AAN 130 replaces AAN 30/B (0008.7427.00) Concerning 19-inch rack installation the AAN 130 requires 1 HU rack space instead of 3 HU required by AAN 30/B.</p> <p>Doc. PIG 010620</p>
AAN 140	2061.0140.00	<p>19-inch 1 HU Remote Power Supply Unit Frequency range 0.01 – 100 MHz</p> <p>The AAN 140 provides 4 remote power feeding ports and 4 receiver ports, typically used with 4 active monopole antennas STA or 2 active dipole antennas HD 1 A or 1 active dipole antenna HD 2 A or 1 active combination antenna HD 2 A + STA ...</p> <p>Doc. PIG 010620</p>

Associated Products (continued)

Type Designation	Part No. NSN	Description
TR 10/E1	0007.3411.00	2" supporting pipe 1 m high, aluminum, RAL 7035 Doc. FIG 010502
RF Coaxial Cable	2078.xxxx.00 ---	Assembled ready-made coaxial cable according to customer specification. Type of connectors and type of cable to be specified by customer.

Compatible Distribution Systems

The following distribution systems match ideally to be fed from the HD series.

Type Designation	Part No.	Description
AVA Series	depends on AVA configuration	<p>Antenna Distributor AVA series for the non-blocking switching and distribution of active and passive antenna signals for up to 20 receiver outputs.</p> <p>Frequency range 0.01 – 30 MHz</p> <p>A separate remote power supply is not needed. The aas.tech active antennas can be directly fed from an AVA series distributor.</p> <p>Doc. PIG 020156</p>
AVB Series	depends on AVB configuration	<p>Antenna Distributor AVB series for the non-blocking switching and distribution of active and passive antenna signals for up to 20 receiver outputs.</p> <p>Frequency range 1.5 – 30 MHz</p> <p>A separate remote power supply is not needed. The aas.tech active antennas can be directly fed from an AVB series distributor.</p> <p>Doc. PIG 020160</p>
AVS 2G Series	depends on AVS 2G configuration	<p>Antenna Distribution System AVS 2G series for the non-blocking switching and distribution of active and passive antenna signals for more than 20 receiver outputs</p> <p>Frequency range A: 0.01 – 30 MHz Frequency range B: 1.5 – 30 MHz</p> <p>Depending on the number of connected active antennas a separate remote power supply is needed.</p> <p>Doc. PIG 020601</p>
AMC A1 Series	depends on AMC configuration	<p>Antenna Distributor AMC A1 series for the distribution of the antenna signal to up to 16 receiver outputs</p> <p>Frequency range 1.6 – 30 MHz</p> <p>A separate remote power supply is not needed. The aas.tech active antennas can be directly fed from an AMC A1 series distributor.</p> <p>Doc. PIG 020802</p>